



## Filtersorb SP3

10" and 14" Quick change filter w/ scale media for temporary hardness using NAC technology

### Overview

Quick-change filters are that in every sense of the word. Whether using the quick connect option or 3/8" threaded head, these filters can be changed within a minute. It's as simple as a twist, remove, insert replacement and twist again. This type of filter is recommended for those who's time is a bit more valuable than money. Filtersorb SP3, a chemical-free scale preventor and remover, which utilizes Nucleation Assisted Crystallization (NAC). NAC is the 3rd generation of this technology. Not to be confused with Template Induced Crystallization (TIC) or Template Assisted Crystallization (TAC), which is the 1st generation technology. NAC utilizes a quicker processing time (3 seconds) than TIC / TAC (10 seconds). Due to the timing, the CO<sub>2</sub> does not blend in the water like TIC / TAC therefore corrosion is not created over time. Unlike Phosphates or ion exchange that sequester molecules within the water, NAC technology encapsulates the water thus keeping the water's natural composition.

Item #	Item Description	GPM	Capacity
SXP-10SPR	10" Filtersorb SP3 filter refill	1.0	4,000
SXP-14SPR	14" Filtersorb SP3 filter refill	2.0	8,000

### Benefits

1. No change in TDS or pH
2. Chemical free
3. Biocides: NAC technology creates CO<sub>2</sub> micro bubbles. CO<sub>2</sub> bubbles actively destroys bacterial membranes acting as a biocide
4. Protects ice machines, boilers, steam generators and coffee equipment against the formation and accumulation of both temporary and permanent scale
5. Rated for water hardness > 26 grains Energy savings - Existing scale removal will allow equipment to operate at maximum efficiency
6. A 99.6% effectiveness rating when tested by an independent laboratory against the international protocol for scale prevention.

# Installation and Operational tips

Filter must be installed vertically

Check inlet pressure is  $\leq$  80 psi (Higher pressure will push the scale media to the top and become lodged, restricting flow)

Installation of a sediment filter is recommended in front on the filter. 0.5-micron sediment filter for ice machines and espresso equipment. 1 – 5-micron sediment filter (based on water quality) for other kitchen equipment

Filter should be preceded by a carbon filter to protect it from Chlorine or Chloramines.

When flow becomes too slow or restricted, first try replacing sediment filter. Then check for Chlorine. If traces found, change carbon filter. If slow flow continues, change filter cartridge

## Notes

Important Notice: Performance claims are based on a complete system, including a filter and connection to a pressurized water source. This filter must be placed in an appropriate system and operated according to the system's specifications in order to deliver the claimed performance. It is essential to follow operational, maintenance, and filter replacement requirements, as directed for each application, for this filter and system to perform correctly. Read the Manufacturer's Performance Data Sheet accompanying the system and change the filter as suggested.

1. Actual results obtained will vary with various combinations of organic contaminants, changes in pH or other conditions encountered in actual use.
2. All information presented here is based on data believed to be reliable. It is offered for evaluation and verification but is not to be considered a warranty of any kind.

## Limited Liability

ScaleX Pro makes no warranties of any kind, expressed or implied, statutory or otherwise, and expressly disclaims all warranties of every kind, concerning the product, including, without limitation, warranties of merchantability and fitness for a particular purpose, except that this product should be capable of performing as described in this product's datasheet. ScaleX Pro's obligation shall be limited solely to the refund of the purchase price or replacement of the product proven defective, at ScaleX Pro's sole discretion. Determination of suitability of this product for uses and applications contemplated by Buyer shall be the sole responsibility of Buyer. Use of this product constitutes Buyer's acceptance of this Limited Liability.

Head compatibility:  
Everpure: QL2 & QL3 heads  
Omnipure

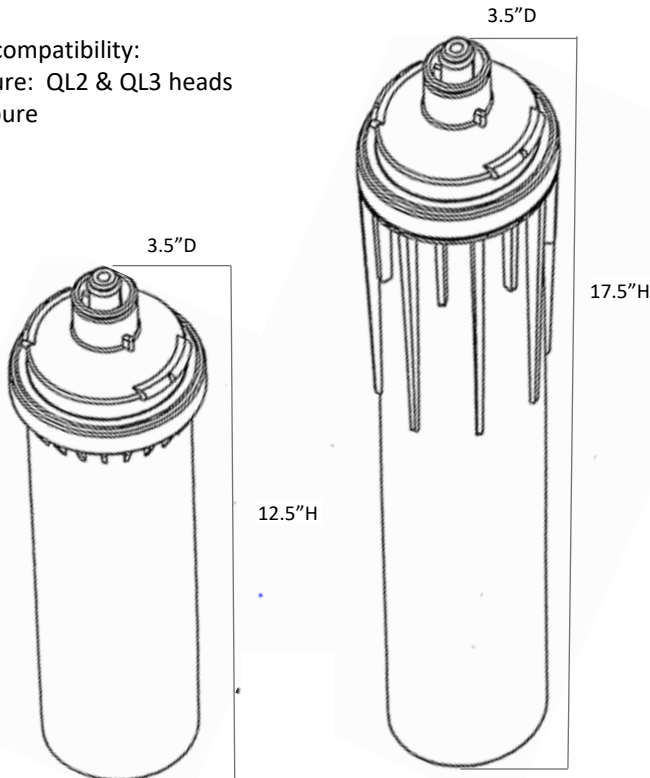

**SCALEXPRO**  
WATER

## Specifications

Minimum Operating Temperature:	40° F / 4° C
Maximum Inlet Temperature:	125° F / 52° C
Minimum Operating Pressure:	20 psig / 1.38 bar
Maximum Operating Pressure:	80 psig / 6.9 bar
Maximum Differential Pressure:	60 psig / 4.14 bar
Collapse Pressure:	150 psig / 10.35 bar

ScaleX Pro filters are not to be autoclaved or steam-sterilized. Use only with microbiologically safe and adequately disinfected water



The filter cartridge is tested and certified by WQA against NSF/ANSI Standard 42 for material safety requirements only.

COMPONENT

## Shipping details

10" filter  
Case count: 12  
Weight: 14 lbs.  
Case dimensions: L: 17" x W: 13" x H: 14"

14" filter  
Case count: 6  
Weight: 18 lbs.  
Each dimensions: L: 18" x W: 14" x H: 17"

[www.Scalexpro.com](http://www.Scalexpro.com)

Gilbert, AZ 85298 (480) 530-7151 ext. 1